

# ENGINE GOVERNING SYSTEMS

## ESD5100 Series Speed Control Unit



- Selectable droop operation.
- Adjustable idle speed.
- Interfaces with accessories.

- Multi-voltage unit.
- Soft coupling option.
- Precise speed control.

### INTRODUCTION

The **ESD5100** Series speed control unit is an all-electronic device designed to control engine speed with fast and precise response to transient load changes. This closed loop control, when connected to a proportional electric actuator and supplied with a magnetic speed sensor signal, will control a wide variety of engines in an isochronous or droop mode. It is designed for high reliability and built ruggedly to withstand the engine environment.

Simplicity of installation and adjustment was foremost in the design. Non-interacting performance controls allow near optimum response to be easily obtained.

Other features include adjustable droop and idle operation, inputs for accessories used in multi-engine or special applications, protection against reverse battery voltage, transient voltages, accidental short circuit of the actuator and fail safe design in the event of loss of speed sensor signal or battery supply.

### DESCRIPTION

Engine speed information for the speed control unit is usually received from a magnetic speed sensor. Any other signal-generating device may be used provided that the generated frequency is proportional to engine speed and meets the voltage input and frequency range specification. The speed sensor is typically mounted in close proximity to an engine driven ferrous gear, usually the engine ring gear. As the teeth of the gear pass the magnetic sensor, a signal is generated which is proportional to engine speed.

Signal strength must be within the range of the input amplifier. An amplitude of 0.5 to 50 volts RMS is required to allow the unit to function within its design specifications. The speed signal is applied to Terminals C and D of the speed control unit. Between these terminals there is an input impedance of over 33,000 ohms. Terminal D is internally connected to Terminal E, battery negative. Only one end of the cable shield should be connected.



When a speed sensor signal is received by the controller, the signal is amplified and shaped by an internal circuit to provide an analog speed signal. If the speed sensor monitor does not detect a speed sensor signal, the output circuit of the speed control unit will turn off all current to the actuator.

A summing circuit receives the speed sensor signal along with the speed adjust set point input. The speed range has a ratio of 9:1 and is adjusted with a 25-turn potentiometer. The output from the summing circuit is the input to the dynamic control section of the speed control unit. The dynamic control circuit, of which the gain and stability adjustments are part, has a control function that will provide isochronous and stable performance for most engine types and fuel systems.

The speed control unit circuit is influenced by the gain and stability performance adjustments. The governor system sensitivity is increased with clockwise relation of the gain adjustment. The gain adjustment has a range of 33:1. The stability adjustment, when advanced clockwise, increases the time rate of response of the governor system to match the various time constants of a wide variety of engines. The speed control unit is a PID device, the "D", derivative portion can be varied when required. (See instability section in PIB1000.)



Governors America Corp. 720 Silver St. Agawam, MA 01001

Tel: 413-786-5600 Fax: 413-786-5666

<http://www.governors-america.com>

E-mail: [info@governors-america.com](mailto:info@governors-america.com)



During the engine cranking cycle, the actuator becomes fully energized and moves to the maximum fuel position. The actuator will remain in this state during engine cranking and acceleration. While the engine is at steady load, the actuator will be energized with sufficient current to maintain the governor speed set point.

The output circuit provides switching current at a frequency of about 500 Hz. to drive the actuator. Since the switching frequency is well beyond the natural frequency of the actuator, there is no visible motion of the actuator output shaft. Switching the output transistors reduces its internal power dissipation for efficient power control. The output circuit can provide current up to 10 amps continuous at 25°C for 12 and 24 VDC battery systems. The actuator responds to the average current to position the engine fuel control lever.

In standard operation, the speed control unit performance is isochronous. Droop governing can be selected by connecting Terminals K and L and the percent of droop governing can be varied with the droop

adjustment control. Connecting Terminals G and H can increase the droop range.

The speed control unit has several performance and protection features, which enhance the governor system. A speed anticipation circuit minimizes speed overshoot on engine startup or when large increments of load are applied to the engine. Engine idle speed can be remotely selected and is adjustable. Accessory inputs to achieve variable speed operation and multi-engine control can be accepted by the ESD5100 Series speed control unit for GAC load sharing module, automatic synchronizer's, ramp generators and other accessory engine control modules. Protection against reverse battery voltage and transient voltages is provided. The design is fail-safe in the event of loss of speed sensor signal or battery supply.

The ESD5100 Series speed control unit is compatible with GOVERNORS AMERICA CORP. proportional electric actuators as well as those from other manufacturers.

**DIAGRAM 1 SYSTEM WIRING/OUTLINE**

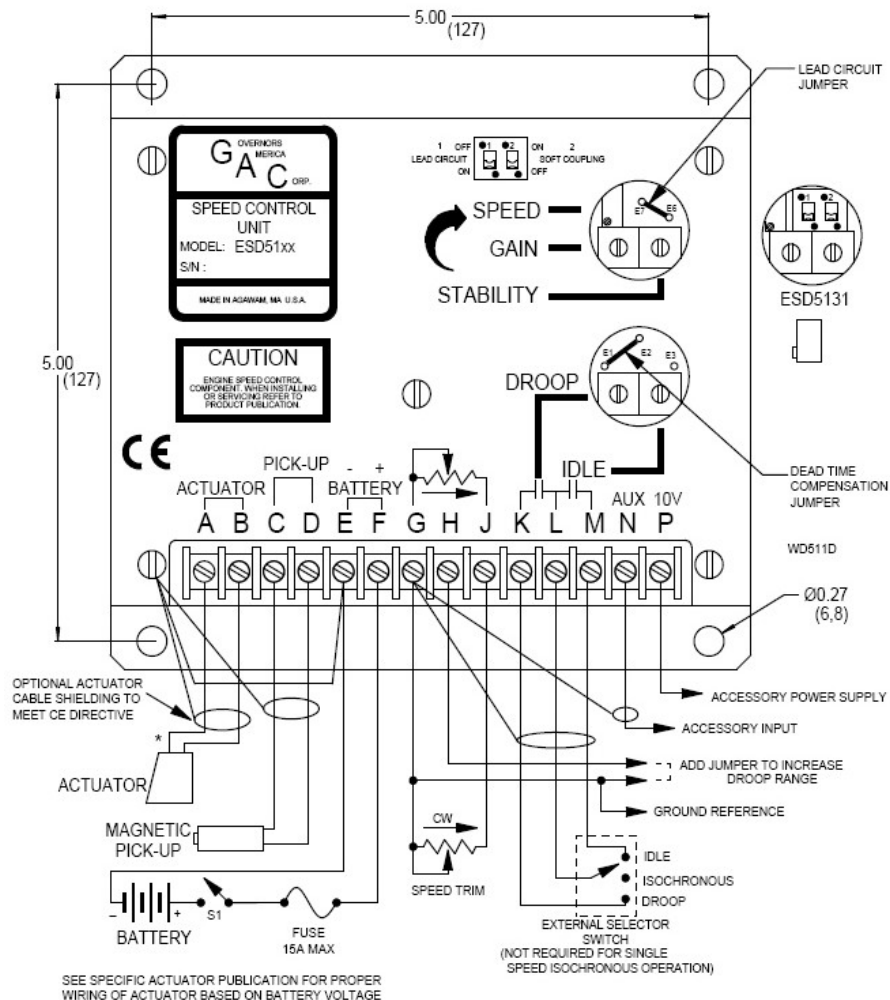

**ESD5100 SERIES SPEED CONTROL UNITS**

ESD5111.....Standard unit	ESD5131.....Speed detector circuit
ESD5111T..... Temperature compensated ESD5111	ESD5131H..... Hard Potted ESD5131
ESD5111H.....Hard potted ESD5111	ESD5150..... 4-20mA input
ESD5119..... EFC reverse acting	ESD5151..... ESD5131 w/expanded range of 10.5kHz
ESD5120..... EFC forward acting/light force	ESD5159..... ESD5111 w/expanded range of 14kHz.
ESD5120T.....Temp Compensated ESD5120	

**SPECIFICATIONS**

**PERFORMANCE**

Isochronous Operation/Steady State Stability .....	0.25% or better
Speed Range/Governor.....	1K-7.5K Hz continuous
Speed Drift with Temperature .....	± .5% Typical
Idle Adjust CW .....	Min. 1200 Hz. Below set speed
Idle Adjust CCW.....	Min. 4100 Hz. Below set speed
Droop Range .....	1 - 5% regulation*
Droop Adj. Max. (K-L Jumpered) .....	875 Hz., ± 75 Hz. per 1.0 A change
Droop Adj. Min. (K-L Jumpered) .....	15 Hz., ± 6 Hz. per 1.0 A change
Speed Trim Range .....	± 200 Hz.
Remote Variable Speed Range .....	500 - 3.7 kHz. or any part thereof
Terminal Sensitivity	
J .....	115 Hz., ± 15 Hz / Volt @ 5.0 K Impedance
L .....	735 Hz., ± 60 Hz / Volt @ 65 K Impedance
N .....	148 Hz., ± 10 Hz / Volt @ 1 Meg. Impedance
P .....	10 VDC Supply @ 20 ma Max.

**ENVIRONMENTAL**

Ambient Operating Temperature Range .....	-40 to +180°F (-40° to +85°C)
Relative Humidity .....	up to 95%
All Surface Finishes .....	Fungus Proof and Corrosion Resistant

**INPUT POWER**

Supply .....	12 or 24 VDC Battery Systems (Transient and Reverse Voltage Protected)**
Polarity .....	Negative Ground (Case Isolated)
Power Consumption .....	50 ma continuous plus actuator current
Actuator Current Range @ 77°F (25°C).....	10 Amps continuous***
Speed Sensor Signal .....	0.5-50 Volts RMS

**RELIABILITY**

Vibration .....	1G @ 20-100 Hz.
Testing .....	100% Functionally Tested

**PHYSICAL**

Dimensions .....	See Outline (DIAGRAM 1)
Weight .....	1.2 lbs. (545 grams)
Mounting.....	Any Position, Vertical Preferred

\*Droop is based on a speed sensor frequency of 4000 Hz. and an actuator current change of 1 amp from no load to full load. Applications with higher speed sensor signals will experience less percentage of droop. Applications with more actuator current change will experience higher percentages of droop. See droop description for specific details on operation of droop ranges. When used with the ADC100 actuator the droop percentage will be less due to the actuators low current consumption.

\*\*Protected against reverse voltage by a series diode. A 15 amp fuse must be installed in the positive battery lead.

\*\*\*Protected against short circuit to actuator (shuts off current to actuator), unit automatically turns back on when short is removed.