

Please read the following instructions and visually inspect this product for damage from shipping before installing. It is your responsibility to have a qualified person install this unit and make sure it conforms to local codes.

The **JDR050** is a generic J1939 diagnostic code reader designed to display the numeric value or the text translation of a trouble code being reported by an engine's electronic control unit (ECU). The unit can read both active and stored codes.

The **JDR050** has user configurable parameters to adjust the unit's behavior. Depending on the configuration, the unit can also be used to reset the stored codes.

DIAGRAM 1. Panel Cutout

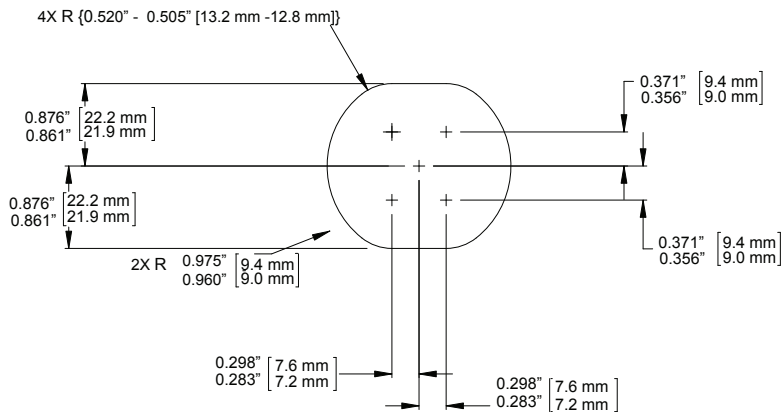
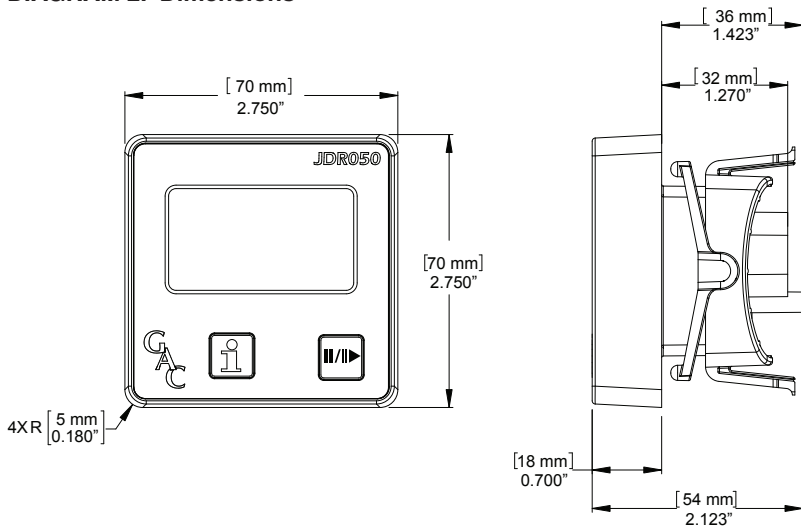

DIAGRAM 2. Dimensions



MOUNTING

To mount the **JDR050** to a panel, (see **DIAGRAM 1.**)

1. Make sure power is turned off.
2. Cut mounting hole, per **DIAGRAM 1.**
3. Slide **JDR050** into hole, making sure the **JDR050** is facing upward and outward.
4. Note the orientation of the slide latch. The releases on the latch are on the top and bottom.
5. While holding the front of the **JDR050**, slide the retaining ring on back until it is snug. Do not over tighten.

CONNECTING*

To connect the **JDR050** to a panel, (see **DIAGRAM 3.**)

1. Note the orientation of the connector from the engine. The release is on the bottom.
2. Plug the engine connector into the left connector on the rear of the **JDR050**. This is the connector with the male pins.
3. Apply power and test the unit.

*Mating harness **OPTIONS** available. See **TABLE 1.**

TABLE 1.

CH417-4572	JDR 15' Cable Harness with Mating Connector and Built-In CAN bus Termination Jumper.
CH418-4572	JDR 15' Cable Harness with Mating Connector - Without Termination.
EC1331	Deutsch DT06-6S Mating Connector for JDR , pins and plugs. Must crimp and assemble connector.

DIAGRAM 3. Connection

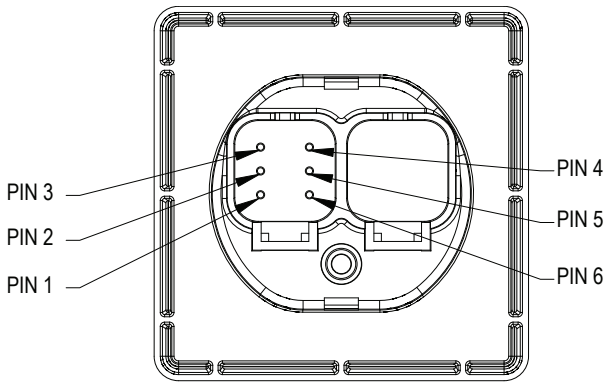

PIN 1	V+
PIN 2	CAN H
PIN 3	CAN L
PIN 4	V-
PIN 5	CAN H TERMINATED
PIN 6	V-

TO TERMINATE CAN JUMPER PIN 2 TO 5

CONNECTING

- The **JDR050** can be configured to listen for a specific ECU or any ECUs (up to 10). If more than 10 ECUs are active simultaneously, the **JDR050** response will be unpredictable.
- A CAN bus termination resistor is included in the **JDR050**. The termination resistor is accessed via the cable harness (see **DIAGRAM 3.**).
- The **JDR050** has an overall IP67 rating, though the back can be IP69K providing a Deutsch connector is used.
- Fits into standard 2" [51mm] panel opening (see **DIAGRAM 1.**).

INTRODUCTION

The **JDR050** is simple to use. It is equipped with two buttons and an LCD display with indicators. Most of the indicators have an LED that will illuminate to draw attention to the failure. The display also supports 6 digits and 4 alpha numeric characters. The 6 digits are used to display numbers such as the **DTCs**. The 4 alpha numeric characters are used to display text such as the **DTC** field identifier (**DTC, FMI, OC, SRC**), or, if text mode is enabled, the description of the field.

The messages displayed on the **JDR050** conform to the SAE J1939 standard. In **Text Translation Mode**, the unit will display the standard text. If an engine manufacturer implements a proprietary **SPN** (not defined in the standard), the **JDR050** will display the **SPN** number without a text translation. Should one of these **DTCs** appear, please consult your engine manufacturer for the definition. With some engine manufacturers, the text of the message can also vary slightly. Should this be the case, please consult the owner's manual for the engine.

TABLE 2. J1939 DEFINITIONS

Acronym	Definition
DTC	Diagnostic Trouble Code – ECU reported failure. DTC 's consists of several parts, an SPN , FMI , OC , SCR .
SPN	Suspect Parameter Number – Parameter being affected.
FMI	Failure Mode Indicator – Description of the failure.
OC	Occurrence Count – The number of times the failure has occurred.
SRC	Source – CAN Address of ECU reporting DTC .
DM1	Active DTCs .
DM2	Stored DTCs (also referred to as "previously active codes").
DM3	J1939 message transmitted to clear stored codes.

DESCRIPTION

- The **JDR050** has four basic modes: **Auto Mode**, **Manual Mode**, **User Configuration Mode**, and **Clear Stored Codes Mode**.
- On **Power-On**, the **JDR050** turns on all the LCD segments and LEDs and then displays the current software version number.
- After **Power-On**, the unit is in **Auto Mode**.
- In **Auto Mode**, the **JDR050** cycles through active **DTCs**. If no **DTCs** are present the unit will display dashes.
- In **Auto Mode**, when the **JDR050** has displayed all the **DTCs**, the unit will display the end of list, indicated by a row of dashes.
- When at the end of the list, if there are stored **DTCs**, the **JDR050** will light the **MEM** indicator.
- **DM1 Messages** (active **DTCs**) are transmitted by the **ECU** and displayed by the **JDR050**.
- **DM2 Messages** (stored **DTCs**) are requested by the **JDR050**.
- If equipped, the **JDR050** has the ability to transmit a **DM3** message (clear stored **DTCs**) though it may not be acknowledged by the **ECU**.
- As defined by J1939, the **JDR050** is equipped with 4 indicator lamps (**Stop**, **Warning**, **Malfunction**, **Protect**). The lighting and flashing of these indicators is commanded by the **ECU**. The **JDR050** does not decide which lamp is lit. It is possible for all to be lit simultaneously.

TABLE 3. BUTTON DESCRIPTION

Symbol	Definition	Description
	Retrieve detailed information	Extracts the next part of the DTC record from the current DTC . Cycles through DTC , FMI , OC , and SRC . Also used to switch the JDR050 into Manual Mode and to clear stored codes.
	Pause / Resume / Next SPN.	Used to switch the JDR050 into Manual Mode , when pressed and held it returns to Auto Mode , and to examine the next DTC in the list (from Manual Mode).

TABLE 4. LED DESCRIPTION

Symbol	Definition	Description
AUTO	Auto Mode	Unit is in Auto Mode .
MAN	Manual Mode	Unit is in Manual Mode .
	CAN bus Traffic Detected	Valid CAN traffic is being received. Primarily used for troubleshooting. If indicator is not lit, the JDR050 is not properly connected to a CAN network, or is not detecting the engine ECU.
J1939	J1939 CAN bus Traffic Detected	CAN traffic has been detected which qualifies as J1939. Primarily for troubleshooting. If the CAN traffic indicator is lit and the J1939 indicator is not lit, it is possible that the engine ECU is not communicating via SAE J1939.
	Busy Indicator	Unit is performing a time consuming operation.
	J1939 Engine Stop Indicator	Lit and/or flashed by engine ECU. See engine manual for definition.
	J1939 Warning Indicator	Lit and/or flashed by engine ECU. See engine manual for definition.
	J1939 Malfunction Indicator	Lit and/or flashed by engine ECU. See engine manual for definition.
	J1939 Protection Indicator	Lit and/or flashed by engine ECU. See engine manual for definition.
	Stored DTC	In Auto Mode , indicates stored codes are present; in Manual Mode indicates the information being displayed is for a stored code.

This document is subject to change without notice.

Caution: None of GAC products are flight certified controls including this item.

PIB 4135 B

AUTO MODE

When the **JDR050** is powered on the unit will go into **Auto Mode**. In this mode the **JDR050** cycles through all of the active **DTCs**. When the end of the list is reached, the unit will display dashes. When at the end of the list, and if there are stored **DTCs** present, the **JDR050** will turn on the **MEM** indicator.

The detailed information about the active **DTCs** and stored **DTCs** can only be examined while in **Manual Mode**. To switch from **Auto Mode** to **Manual Mode**, press either button. The **JDR050** will display the current active **SPN**. To return to **Auto Mode**, from **Manual Mode**, you can press and hold the **SPN** button for 3 seconds, or, the unit will automatically return to **Auto Mode** when the unit detects no user activity for the amount of time specified by the **IDLE User Configurable Parameter**.

MANUAL MODE

Manual Mode is used to examine the active and stored **DTCs**. To enter **Manual Mode** from **Auto Mode**, press **i** or **||/▶**. Subsequent presses of the **i** button will reveal the underlying information for the **DTC**. The order this information is displayed is: **SPN**, **FMI**, **OC**, and **SRC**. Once the **SRC** is displayed, pressing the **i** button will again display the **SPN** for the same **DTC**.

The **JDR050** will start displaying the information of the current active **DTC**. By pressing the **||/▶** button the **JDR050** will go to the next active **SPN**. When the **JDR050** reaches the end of the active **DTCs**, the **JDR050** will begin displaying stored **DTCs** (should there be any). These will be indicated by the **MEM** indicator. When the last stored **DTCs** is reached, the **JDR050** will restart displaying the active **DTCs** at the beginning of the list.

ENTER USER CONFIGURATION MODE

To enter **User Configuration Mode**, first enter **Manual Mode**. This is done by pressing either the **i** or the **||/▶** button. Next, simultaneously hold **i** and **||/▶** for 3 seconds.

To cycle through the different configurable parameters, press the **||/▶**. When you reach the end of the list, the **JDR050** will restart from the first configurable parameter.

To change a value of a configurable parameter, press the **i** button. The **JDR050** will select the next valid parameter. **Care should be taken when changing the engine ECU and JDR050 CAN bus addresses.** If not properly set, the **JDR050** may not appear to be functioning. See **TABLE 5**, for a list of configurable parameters.

TABLE 5. CONFIGURABLE PARAMETERS

ID	TEXT	DEFINITION	VALID RANGE	DEFAULT
10	ECU	CAN Address of ECU (255 accepts any address)	0-255	255
11	JDR	CAN Address for JDR050	0-254	201
12	RATE	Length of time JDR will display DTC (in seconds)	1-10 s (1 second intervals)	2 s
13	IDLE	Amount of idle time before JDR returns to previous state	5-60 s (5 second intervals)	10 s
14	DTCs	Maximum number of DTCs the JDR will accept	10, 25, 50, 100, 200, 240	240
15	TEXT	Scroll rate for text display of SPNs and FMIs	0-5 (0=no text, 1=fast, 5=slow)	2
16	CONV	J1939 Conversion Method (only necessary for older engines that do not support conversion method 4)	1, 2, 3	1

CLEARING STORED DTCs

(Contact GAC for details.)

If the engine allows the clearing of stored **DTCs** and the **JDR050** is equipped with this feature, use the following process to send the **DM3** (clear stored **DTCs**). First, put the unit into **Manual Mode** by pressing either the **i** or the **||/▶** button. Press and hold **i** for 3 seconds - unit will then display **DM3**. Press and hold **i** for another 3 seconds, unit will then say **SENT**. From this screen, you can only return to **Manual Mode**. To do this press and hold the **||/▶** button for 3 seconds, or, the unit will automatically return to **Manual Mode** when the unit detects no user activity for the amount of time specified by the **IDLE User Configurable Parameter**.

FMI TEXT

The **JDR050** can only display 4 text characters at any one time. Because of this limitation, **GAC** has opted to shorten the text of the standard **FMI** text. (See **TABLE 6**. For detailed information regarding the **FMI** definitions please consult the SAE J1939 specification).

TABLE 6. CONFIGURABLE PARAMETERS

FMI	ABBREVIATED FMI TEXT	STANDARD J1939 FMI TEXT
0	DATA ABOVE NORMAL - MOST SEVERE	Data valid but above normal operational range – Most Severe Level
1	DATA BELOW NORMAL - MOST SEVERE	Data valid but below normal operational range – Most Severe Level
2	BAD DATA	Data erratic, intermittent, or incorrect
3	VOLTAGE ABOVE NORMAL	Voltage above normal or shorted to high source
4	VOLTAGE BELOW NORMAL	Voltage below normal or shorted to low source
5	CURRENT BELOW NORMAL	Current below normal or open circuit
6	CURRENT ABOVE NORMAL	Current above normal or grounded circuit
7	MECHANICAL FAILURE	Mechanical system not responding or out of adjustment
8	ABNORMAL FREQUENCY/PULSE WIDTH	Abnormal frequency or pulse width or period
9	ABNORMAL UPDATE RATE	Abnormal update rate
10	ABNORMAL RATE OF CHANGE	Abnormal rate of change
11	UNKNOWN CAUSE	Root cause not known
12	BAD DEVICE/COMPONENT	Bad intelligent device or component
13	CALIBRATION NEEDED	Out of calibration
14	SPECIAL INSTRUCTIONS	Special instructions
15	DATA ABOVE NORMAL - LEAST SEVERE	Data valid but above normal operating range – least severe level
16	DATA ABOVE NORMAL - MODERATELY SEVERE	Data valid but above normal operating range – moderately severe level
17	DATA BELOW NORMAL - LEAST SEVERE	Data valid but below normal operating range – least server level
18	DATA BELOW NORMAL - MODERATELY SEVERE	Data valid but below normal operating range – moderately severe level
19	NETWORK DATA ERROR	Received network data in error
20	DATA DRIFTED HIGH	Data drifted high
21	DATA DRIFTED LOW	Data drifted low
22-30	RESERVED 20 – RESERVED 30	Reserved for SAE assignment
31	CONDITION EXISTS	Condition Exists

This document is subject to change without notice.

Caution: None of GAC products are flight certified controls including this item.

PIB 4135 B

TROUBLESHOOTING

SYMPTOMS	POSSIBLE PROBLEMS
Unit not operating / Backlight not on.	<ul style="list-style-type: none"> • Check DC power
Unit powers on but CAN indicator is not on.	<ul style="list-style-type: none"> • Make sure the ECU is enabled. • Check the polarity of CAN High and CAN Low. • Check to make sure the CAN network has the proper resistance of 60 ohms between CAN High and CAN Low when all devices on the CAN network are powered off.
CAN indicator on but is not receiving J1939 messages.	<ul style="list-style-type: none"> • Check that ECU is a J1939 ECU. • Check the user configuration parameter 'ECU'. Make sure it is set to 255 or the CAN address of the engine ECU.
SPNs, which an ECU should not be reporting, are being displayed.	<ul style="list-style-type: none"> • Check the age of the engine. If it does not support J1939 Conversion Method 4, then configure the unit with either conversion methods 1, 2, or 3.
No text is being scrolled when examining the SPN or FMI.	<ul style="list-style-type: none"> • The unit is not equipped to display the text of the SPN and FMI. • If the unit is equipped, in User Configuration Mode, make sure the TEXT parameter is not set to 0.
The SPN and FMI text scrolls to fast or to slow. The SPN and FMI text scrolls to fast or to slow.	<ul style="list-style-type: none"> • In User Configuration Mode, adjust the TEXT parameter up or down accordingly.
Clear Stored Codes key sequence does not work.	<ul style="list-style-type: none"> • Unit is not equipped with that function.
DM3 is sent to the engine, but the stored codes are not cleared.	<ul style="list-style-type: none"> • The engine manufacturer has secured the engine, and does not allow the DM3 message to be executed.

SPECIFICATIONS

Power Input

Operating Voltage 8-32 VDC (0V 50ms transient condition)
 Current Draw 0.25 Amp @ 12V
 Reverse polarity protected

Physical

Overall 2.75" x 2.75" x 2.123" (70mm x 70mm x 54mm)
 Front to Back 2.75" x 2.75" x 0.7" (70mm x 70mm x 18mm)
 Panel opening 2" Round (51mm)

CAN bus

J1939 SAE Compliant (V1 when CM=1, V4 when CM=0)
 120 CAN bus termination resistor included

Environmental

Ambient Temperature Range -40° to +85°C (-40° to +185°F)
 Relative Humidity Up to 100%
 IP67 Front Resist Direct Spray
 IP69K Rear (w. Deutsch connector) Sealed (no fogging)
 Shock/Vibe TBD