

Please read the following instructions and visually inspect this product for damage from shipping before installing. It is your responsibility to have a qualified person install this unit and make sure it conforms to local codes.

The **JDR100**, GAC's J1939 dual function data reader, is a low-cost universal device that allows users to read standard J1939 engine parameters and **Diagnostic Trouble Codes (DTC's)** from engines equipped with J1939 compatible **Electronic Control Units (ECU)**. The **JDR100** supports six live engine parameters (RPM, Oil Pressure, Coolant Temperature, Fuel Level, Battery Voltage, Engine Run Hours) along with J1939 stop, warning, malfunction, and protection status messages. If enabled, the **JDR100** will display the text translation of the engine parameter or trouble code information.

DIAGRAM 1. Panel Cutout

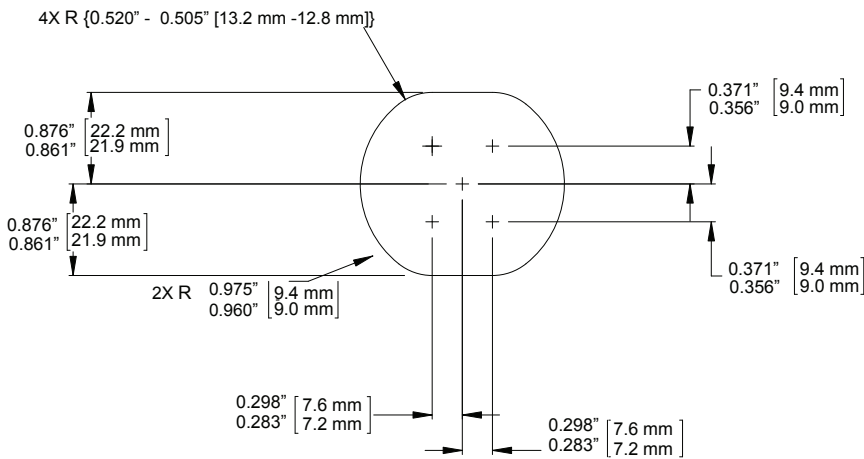

MOUNTING

To mount the **JDR100** to a panel. (see **DIAGRAM 1.**)

1. Make sure power is turned off.
2. Cut mounting hole, per **DIAGRAM 1.**
3. Slide **JDR100** into hole, making sure the **JDR100** is facing upward and outward.
4. Note the orientation of the slide latch. The releases on the latch are on the top and bottom.
5. While holding the front of the **JDR100**, slide the retaining ring on back until it is snug. Do not over tighten.

DIAGRAM 2. Dimensions

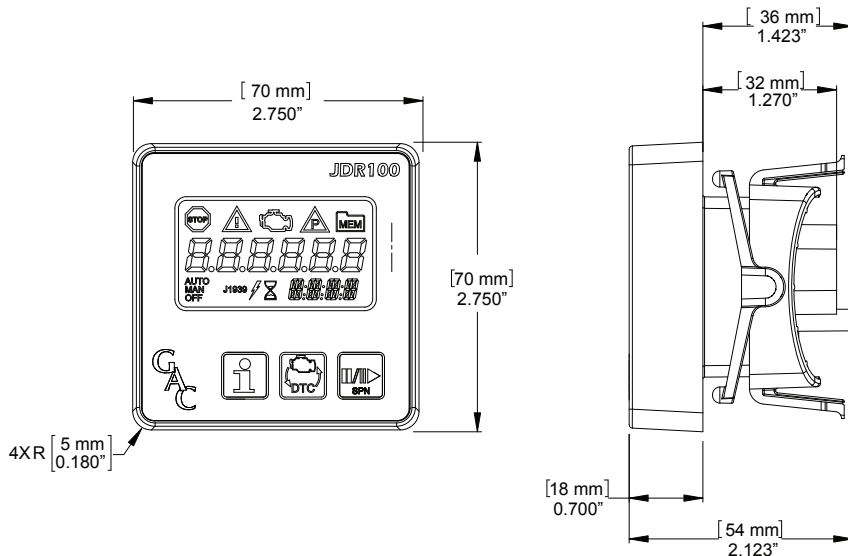

CONNECTING*

To connect the **JDR100** to a panel. (see **DIAGRAM 3.**)

1. Note the orientation of the connector from the engine. The release is on the bottom.
2. Plug the engine connector into the left connector on the rear of the **JDR100**. This is the connector with the male pins.
3. Apply power and test the unit.

*Mating harness **OPTIONS** available. See **TABLE 1.**

TABLE 1.

CH417-4572	JDR 15' Cable Harness with Mating Connector and Built-In CAN bus Termination Jumper.
CH418-4572	JDR 15' Cable Harness with Mating Connector - Without Termination.
EC1331	Deutsch DT06-6S Mating Connector for JDR, pins and plugs. Must crimp and assemble connector.

DIAGRAM 3. Connection*

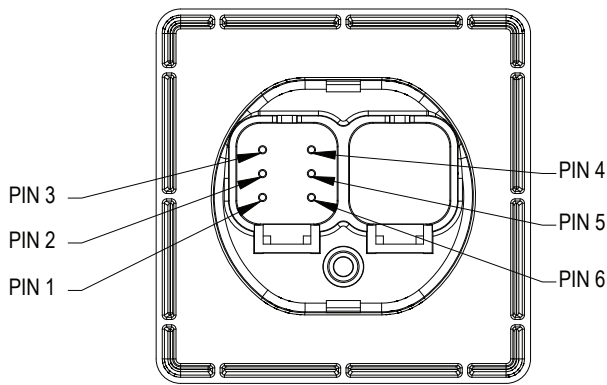

PIN 1	V+
PIN 2	CAN H
PIN 3	CAN L
PIN 4	V-
PIN 5	CAN H TERMINATED
PIN 6	V-

TO TERMINATE CAN JUMPER PIN 2 TO 5

*Mating harness OPTIONS available. See TABLE 1.

TABLE 2. J1939 DEFINITIONS

Acronym	Definition
DTC	Diagnostic Trouble Code – ECU reported failure. DTC 's consists of several parts, an SPN , FMI , OC , SCR .
SPN	Suspect Parameter Number – Parameter being affected.
FMI	Failure Mode Indicator – Description of the failure.
OC	Occurrence Count – The number of times the failure has occurred.
SRC	Source – CAN Address of ECU reporting DTC .
DM1	Active DTCs .
DM2	Stored DTCs (also referred to as "previously active codes").
DM3	J1939 message transmitted to clear stored codes.

DESCRIPTION

The **JDR100**, GAC's J1939 dual function data reader, is a low-cost universal device that allows users to read standard J1939 **Engine Parameters** and **Diagnostic Trouble Codes (DTC's)** from engines equipped with J1939 compatible Electronic Control Units (ECU). The **JDR100** supports six live engine parameters (RPM, Oil Pressure, Coolant Temperature, Fuel Level, Battery Voltage, Engine Run Hours) along with J1939 stop, warning, malfunction, and protection status messages. Because the **JDR100** is a universal diagnostic code reader, its application is not limited to any particular engine manufacturer or engine size. It is easily installed, which makes it ideal for aftermarket prospects, and, it's extremely rugged so off-road applications are never an issue for this device.

J1939 **DTC's** are divided into two categories, **active** and **stored** (also referred to as previously active). **Active codes** are present when a condition is present. **Stored codes** are a record that the condition occurred. Within each **DTC**, active or stored, there are several distinct data components, the **Suspect Parameter Number (SPN)** the **Failure Mode Indicator (FMI)**, the **Occurrence Count (OC)**, and the **Source Address (SRC)**. The **SPN** is the engine parameter that is out of range (e.g., **Oil Pressure**, **Coolant Temperature**). The **FMI** provides information about the failure (e.g., **OUT OF CALIBRATION**). The **OC** indicates the number of times the failure has occurred, and the **SRC** tells the user the CAN address of the offending device. Note, the **JDR100** can display up to 240 **DTCs** from up to 10 different CAN devices.

If enabled, the **JDR100** will display the text translation of the engine parameter or trouble code information.

INTRODUCTION

The **JDR100** reads and displays live engine parameters and **DTCs** transmitted by the engine ECU. The  button is provided to switch between these two display functions.

DISPLAYING ENGINE PARAMETERS - While performing the live engine parameter display function, the **JDR100** accepts RPM, Oil Pressure, Coolant Temperature, Fuel Level, and Battery Voltage messages from the engine ECU. The **JDR100** has its own internal memory to maintain engine run hours. Note, not all engine ECUs supply Fuel Level and Battery Voltage. The order in which each parameter is displayed can be configured by the user. In **Auto Mode**, while displaying engine parameters, the **JDR100** continuously scrolls through each parameter. The **JDR100** will also illuminate the J1939 indicators, should the ECU make the request. The **JDR100** can be configured to display parameter units in C° / Bar or F° / PSI.

DISPLAYING DTCs - The **JDR100** will accept J1939 **DM1** and **DM2** messages containing the **DTCs**. The **DTCs** within the **DM1** messages are active codes. The **DTCs** within the **DM2** messages contain the stored codes. In **Auto Mode** while displaying **DTCs**, the **JDR100** continually scrolls through the active **DTCs**. When at the end of the list, and if a stored **DTC** is present, the **JDR050** turns on the **MEM** indicator.



To access the information within the **DTC**, the user enters **Manual Mode** by pressing the  button, or by pressing the  button. When in manual mode, the **JDR100** will cycle through the J1939 **Failure Mode Indicator (FMI)**, the **Occurrence Count (OC)**, and the **Source (SRC)** address of the **DTC** with each press if the  button. If the **J1939 Text Translation** is enabled, the **JDR100** will scroll the standard English text for the **SPN** and **FMI**. To return to **Auto Mode** the user can press and hold the **SPN** button for 3 seconds; the unit will also return to **Auto Mode** if no button is pressed within the number of seconds specified by the return to auto parameter. While in **Manual Mode** and viewing **DTCs**, the user can loop through the list of **SPNs** by pressing the **SPN** button.

TABLE 3. BUTTON DESCRIPTION









Symbol	Definition	Description
	Retrieve detailed information	Extracts the next part of the DTC record from the current DTC . Cycles through DTC , FMI , OC , and SRC . Also used to switch the JDR100 into Manual Mode & to clear stored codes.
	Change Function of Reader	This button is used to alternate viewing between live engine parameters and diagnostic trouble codes.
	Pause / Resume / Next SPN	Used to switch the JDR100 into Manual Mode , when pressed and held it returns to Auto Mode , and to examine the next SPN in the list (from Manual Mode).

TABLE 4. LED DESCRIPTION

Symbol	Definition	Description
AUTO	Auto Mode	Unit is in Auto Mode .
MAN	Manual Mode	Unit is in Manual Mode .
	CAN bus Traffic Detected	Valid CAN traffic is being received. Primarily used for troubleshooting. If indicator is not lit, the JDR100 is not properly connected to a CAN network, or is not detecting an ECU.
J1939	J1939 CAN bus Traffic Detected	CAN traffic has been detected which qualifies as J1939. Primarily for troubleshooting. If the CAN traffic indicator is lit and the J1939 indicator is not lit, it is possible that an ECU is not communicating via SAE J1939.
	Busy Indicator	Unit is performing a time consuming operation.
	J1939 Engine Stop indicator	Lit and/or flashed by engine ECU. See engine manual for definition.
	J1939 Warning indicator	Lit and/or flashed by engine ECU. See engine manual for definition.
	J1939 Malfunction indicator	Lit and/or flashed by engine ECU. See engine manual for definition.
	J1939 Protection indicator	Lit and/or flashed by engine ECU. See engine manual for definition.

This document is subject to change without notice.

Caution: None of GAC products are flight certified controls including this item.

PIB 4136 A

USER CONFIGURATION

A **User Configuration Mode** is made available to adjust the behavior of the **JDR100**. To enter this mode, the **JDR100** must be in **Manual Mode** and then by simultaneously holding the **i** and **|||▶** buttons for 3 seconds.

Once in this user configuration mode, the user can establish the **CAN** address for the **JDR100** the **ECU** has been assigned to, the max number of **DTCs** to be displayed, the number of seconds the unit waits before it returns to **Auto Mode**, the number of seconds the unit will display a given **SPN** (when in **Auto Mode**), and the rate at which to scroll the text. The user can also select the function to display on power up (engine parameters or **DTCs**), the number of seconds to display each engine parameter before switching to the next parameter (when in **Auto Mode**), the display units (standard or metric), and the priority for each of the live engine parameters.

USER OPERATION

The **JDR100** is simple to use. It is equipped with three buttons and an LCD display with indicators. Most of the indicators have an LED that will illuminate to draw attention to the failure. The display also supports 6 digits and 4 alpha numeric characters. The 6 digits are used to display numbers such as the live engine parameters and **DTCs**. The 4 alpha numeric characters are used to display text such as the **RPM**, **OIL**, and **DTC** field identifiers (**DTC**, **FMI**, **OC**, **SRC**), or, if text mode is enabled, the description of the field.

The messages displayed on the **JDR100** conform to the SAE J1939 standard. In text translation mode, the unit will display the standard text. If an engine manufacturer implements a proprietary **SPN** (not defined in the standard), the **JDR100** will display the **SPN** number without a text translation. Should one of these **DTCs** appear, please consult your engine manufacturer for the definition. With some engine manufacturers, the text of the message can also vary slightly. Should this be the case, please consult the owner's manual for the engine.

LIVE ENGINE PARAMETERS / DTCs

When powered on, the unit will illuminate all segments of the LCD display, power on all LED indicators then display the current version of the software. This gives the user the opportunity to verify the validity of these components. After showing the version number the **JDR100** will go into **Auto Mode** displaying live engine parameters (by default). To switch to **DTC** display mode, press the **|||▶** button.

AUTO MODE

Both display functions of the **JDR100** support **Auto Mode**. While in this mode, the **JDR100** will cycle through the parameters of the given function. For example, when displaying live engine parameters the **JDR100** will display **RPM**, **Oil Pressure**, **Coolant Temperature**, **Battery Voltage**, **Engine Run Hours** and **Fuel Level** (providing these parameters are supported by the engine ECU). While displaying **DTCs**, the **JDR100** will cycle through all of the active **DTCs**.

When the end of the list is reached, the unit will display dashes. While at the end of the list, and if there are stored **DTCs** present, the **JDR100** will turn on the **MEM** indicator.

The detailed information about the active **DTCs** and stored **DTCs** can only be examined while in **Manual Mode**. To switch from **Auto Mode** to **Manual Mode**, press either button. The **JDR100** will display the current active **SPN**. To return to **Auto Mode**, from **Manual Mode**, you can press and hold the **SPN** button for 3 seconds, or, the unit will automatically return to **Auto Mode** when the unit detects no user activity for the amount of time specified by the **IDLE** user configurable parameter.

MANUAL MODE

Manual Mode is used to step through the individual live engine parameters or to examine the active and stored **DTCs**. To enter **Manual Mode** from **Auto Mode**, press **i** or **|||▶**. When looking at the live engine parameters, pressing the **i** button will display the text for the parameter being displayed. When looking at **DTCs**, subsequent presses of the **i** button will reveal the underlying information for the **DTC**. The order this information is displayed is: **SPN**, **FMI**, **OC**, and **SRC**. Once the **SRC** is displayed, pressing the **i** button will again display the **SPN** for the same **DTC**.

When displaying **DTCs**, the **JDR100** will start displaying the information of the current active **DTC**. By pressing **|||▶** button, the **JDR100** will go to the next active **SPN**. When the **JDR100** reaches the end of the active **DTCs**, the **JDR100** will begin displaying stored **DTCs** (should there be any). These will be indicated by the **MEM** indicator. When the last stored **DTCs** is reached, the **JDR100** will restart displaying the active **DTCs** at the beginning of the list.

To return to **Auto Mode**, from **Manual Mode**, you can press and hold the **|||▶** button for 3 seconds, or, the unit will automatically return to **Auto Mode** when the unit detects no user activity for the amount of time specified by the **IDLE User Configurable Parameter**.

ENTER USER CONFIGURATION MODE

To enter **User Configuration Mode**, first enter **Manual Mode**. This is done by pressing either the **i** or the **|||▶** button. Next, simultaneously hold **i** and **|||▶** for 3 seconds.

To cycle through the different configurable parameters, press the **|||▶**. When you reach the end of the list, the **JDR100** will restart from the first configurable parameter.

To change a value of a configurable parameter, press the **i** button. The **JDR100** will select the next valid parameter. **Care should be taken when changing the engine ECU and JDR100 CAN bus addresses.** If not properly set, the **JDR100** may not appear to be functioning.

See **TABLE 5.** for a list of configurable parameters.

TABLE 5. CONFIGURABLE PARAMETERS

ID	TEXT	DEFINITION	VALID RANGE	DEFAULT
10	ECU	CAN Address of ECU (255 accepts any address)	0-255	255
11	JDR	CAN Address for JDR100	0-254	201
12	RATE	Length of time JDR will display DTC (in seconds)	1-10 s (1 second intervals)	2 s
13	IDLE	Amount of idle time before JDR returns to previous state	5-60 s (5 second intervals)	10 s
14	DTCS	Maximum number of DTCs the JDR will accept	10, 25, 50,100, 200, 240	240
15	TEXT	Scroll rate for text display of SPNs and FMIs	0-5 (0=no text, 1=fast, 5=slow)	2
16	CONV	J1939 Conversion Method (for engines that do not support conversion method 4)	1, 2, 3	1
17	DISP	Set the display mode on power up to either engine parameters or DTCs.	0 = Engine Parameters 1 = DTCs	0
18	EDRT	Number of seconds to wait before switching to next engine parameter.	0-10 Sec (Continuous 1 sec increments; set to 0 unit will stay on current parameter)	5
19	UNIT	Configures JDR100 to display engine parameters in standard or metric units.	0 = Standard (F° / PSI) 1=Metric (C° / Bars)	0
20	P:RPM	The priority number assigned to the engine speed parameter.	0-10 (0 = do not display)	The lower the number the sooner it appears in the list of parameters.
21	P:OIL	The priority number assigned to the oil pressure parameter.	0-10 (0 = do not display)	
22	P:TMP	The priority number assigned to the coolant temperature parameter.	0-10 (0 = do not display)	
23	P:HRS	The priority number assigned to the engine hours parameter.	0-10 (0 = do not display)	
24	P:BAT	The priority number assigned to the battery voltage parameter.	0-10 (0 = do not display)	
25	P:FUL	The priority number assigned to the fuel level parameter.	0-10 (0 = do not display)	

This document is subject to change without notice.

Caution: None of GAC products are flight certified controls including this item.

PIB 4136 A

CLEARING STORED DTCS *(Contact GAC for details.)*

If the engine allows the clearing of stored **DTCs** and the **JDR100** is equipped with this feature, use the following process to send the DM3 (clear stored DTCs). First, set the **JDR100** to view **DTCs**, then put the unit into **Manual Mode** by pressing either the **i** or the **||▶** button. Press and hold **i** for 3 seconds - unit will then display **DM3**. Press and hold **i** for another 3 seconds, unit will then say SENT.

From this screen, you can only return to **Manual Mode**. To do this press and hold the **SPN** button for 3 seconds, or, the unit will automatically return to **Manual Mode** when the unit detects no user activity for the amount of time specified by the **IDLE User Configurable Parameter**.

RESET ENGINE RUN HOURS

The **JDR100** is equipped with a counter to record the number of hours an engine has run. If the engine **ECU** provides the hours, the **JDR100** will record the value from the **ECU**. If hours are not provided by the **ECU**, the **JDR100** will increment the counter, when it sees engine speed. To reset this counter, first, set the **JDR100** to view live engine parameters, then put the unit into **Manual Mode** by pressing either the **i** or the **||▶** button. Press and hold **i** for 3 seconds - unit will then display **HRS**. Press and hold **i** for another 3 seconds, unit will then say DONE.

From this screen, you can only return to **Manual Mode**. To do this, press and hold the **SPN** button for 3 seconds, or, the unit will automatically return to **Manual Mode** when the unit detects no user activity for the amount of time specified by the **IDLE User Configurable Parameter**.

SPECIFICATIONS

Power Input

Operating Voltage 8-32 VDC (0V 50ms transient condition)
Current Draw 0.25 Amp @ 12V
Reverse polarity protected

Physical

Overall 2.75" x 2.75" x 2.123" (70mm x 70mm x 54mm)
Front to Back 2.75" x 2.75" x 0.7" (70mm x 70mm x 18mm)
Panel Opening 2" Round (51mm)

CAN bus

J1939 SAE Compliant (V1 when CM=1, V4 when CM=0)
120 CANbus termination resistor included

Environmental

Ambient Temperature Range -40° to +85°C (-40° to +185°F)
Relative Humidity Up to 100%
IP67 Front Resist Direct Spray
IP69K Rear (w. Deutsch connector) Sealed (no fogging)
Shock/Vibe TBD

TROUBLESHOOTING

To cycle through the different configurable parameters, press the **||▶** button. When you reach the end of the list, the **JDR100** will restart from the first configurable parameter. To change a value of a configurable parameter, press the **i** button. The **JDR100** will select the next valid parameter. Care should be taken.

FMI TEXT

The **JDR100** can only display 4 text characters at any one time. Because of this limitation, GAC has opted to shorten the text of the standard FMI text. (See **TABLE 6**. for detailed information regarding the **FMI** definitions please consult the SAE J1939 specification).

TABLE 6. FMI Definition

FMI	ABBREVIATED FMI TEXT	STANDARD J1939 FMI TEXT
0	DATA ABOVE NORMAL - MOST SEVERE	Data valid but above normal operational range
1	DATA BELOW NORMAL - MOST SEVERE	Data valid but below normal operational range
2	BAD DATA	Data erratic, intermittent, or incorrect
3	VOLTAGE ABOVE NORMAL	Voltage above normal or shorted to high source
4	VOLTAGE BELOW NORMAL	Voltage below normal or shorted to low source
5	CURRENT BELOW NORMAL	Current below normal or open circuit
6	CURRENT ABOVE NORMAL	Current above normal or grounded circuit
7	MECHANICAL FAILURE	Mechanical system not responding or out of adjustment
8	ABNORMAL FREQ/PULSE WIDTH	Abnormal frequency or pulse width or period
9	ABNORMAL UPDATE RATE	Abnormal update rate
10	ABNORMAL RATE OF CHANGE	Abnormal rate of change
11	UNKNOWN CAUSE	Root cause not known
12	BAD DEVICE/COMPONENT	Bad intelligent device or component
13	CALIBRATION NEEDED	Out of calibration
14	SPECIAL INSTRUCTIONS	Special instructions
15	DATA ABOVE NORMAL - LEAST SEVERE	Data valid but above normal operating range
16	DATA ABOVE NORMAL MODERATELY SEVERE	Data valid but above normal operating range
17	DATA BELOW NORMAL - LEAST SEVERE	Data valid but below normal operating range
18	DATA BELOW NORMAL MODERATELY SEVERE	Data valid but below normal operating range
19	NETWORK DATA ERROR	Received network data in error
20	DATA DRIFTED HIGH	Data drifted high
21	DATA DRIFTED LOW	Data drifted low
22-30	RESERVED 20 – RESERVED 30	Reserved for SAE assignment
31	CONDITION EXISTS	Condition Exists

SYMPTOMS	POSSIBLE PROBLEMS
Unit not operating / Backlight not on.	• Check DC power
Unit powers on but CAN indicator is not on.	• Make sure the ECU is enabled. • Check the polarity of CAN High and CAN Low. • Check to make sure the CAN network has the proper resistance of 60 ohms between CAN High and CAN Low when all devices on the CAN network are powered off.
CAN indicator on but is not receiving J1939 messages	• Check that the ECU is a J1939 ECU. • Check the user configuration parameter 'ECU'. Make sure it is set to 255 or the CAN address of the engine ECU.
SPNs, which an ECU shouldn't be reporting, are being displayed.	• Check the age of the engine. If it does not support J1939 Conversion Method 4, then configure the unit with either conversion methods 1, 2, or 3.
No text is being scrolled when examining the SPN or FMI	• The unit is not equipped to display the text of the SPN and FMI. • If the unit is equipped, in User Configuration Mode, make sure the TEXT parameter is not set to 0.
Live engine parameter not being displayed (e.g., RPM)	• Check that JDR100 user configuration for the parameter is not set to 0. • Verify that the engine ECU transmits the parameter. For example, some engines do not report fuel level or battery voltage.
JDR100 is not displaying the live parameters in the proper units	• Check the JDR100 "UNIT" user configuration parameter (ID 19). It should be set to 0 for F° / PSI, and should be set to 1 for C° / Bars.
On power up JDR100 is displaying DTCs.	• Check the JDR100 "DISP" user configuration parameter (ID 17). It should be set to 0 to display live engine parameters on power up.
The JDR100 is not cycling through the live engine parameters	• Check the EDRT user configuration parameter (ID 18). If it is set to 0, the JDR100 requires the SPN button to be pressed to cycle through the parameters. • Check the user configured priorities (ID's 20-25) of each of the live engine parameters. If priority is set to 0, then the parameter will not be viewed.
The SPN and FMI text scrolls to fast or to slow.	• In User Configuration Mode, adjust the TEXT parameter up or down accordingly.
Clear Stored Codes key sequence does not work.	• Unit is not equipped with that function.
DM3 is sent to the engine, but the stored codes are not cleared.	• The engine manufacturer has secured the engine, and does not allow the DM3 message to be executed.

This document is subject to change without notice.
Caution: None of GAC products are flight certified controls including this item.

PIB 4136 A