

ACB2001 Series Electric Actuator

+1 413 233 1888

www.governors-america.com

1 OVERVIEW

GAC's ACB2001 actuator is a rotary output, 24 V, linear torque proportional electric servo designed for mechanical actuation of fuel system control levers requiring torques in the 16.3 N·m range.

Energized by GAC's ESD5300 Series speed control units, the actuator is capable of 35 degrees of rotation with torques as high as 16.3 N·m. Internal springs provide fail safe operation by forcing the actuator to the fuel shut off position when the actuator is de-energized.

Since the design has no sliding parts, and is totally sealed, its reliability is outstanding and no maintenance necessary. Universal engine applications include large pumps, dual medium carburetors, and some large size carburetors.

- ♦ Rapid Response to Transient Conditions
- ♦ Multiple Mounting Positions
- ♦ High Performance Anti-Corrosive Grease (Lubriplate SYNEME HD-2™)
- ♦ Universal Design
- ♦ Internal Return Spring
- ♦ 35 Rotation
- ♦ Heavy Duty Bearings (ABC2001-HP)



2 SPECIFICATIONS

PERFORMANCE	
Available Torque	MAX 12 lb-ft [16.3 N·m]
Maximum Angular Travel of Shaft	35 ° ±1 ° CW/CCW
POWER INPUT	
Operating Voltage	Nominal 24 V
Normal Operating Current	Up to 5 A
Maximum Stall Current (Short Duration)	Up to 12 A
ENVIRONMENT	
Operating Temperature Range	-65 to 200 °F [-54 to 95 °C]
Relative Humidity	Up to 100 %
All Surface Finishes	Fungus Proof and Corrosion Resistant

PHYSICAL	
Dimensions	Section 3, OUTLINE DIAGRAM
Weight	30 lbf [13.6 kgf]
RELIABILITY	
Vibration	Up to 20 g, 50 - 500 Hz
Testing	100 % Tested

3 OUTLINE DIAGRAM

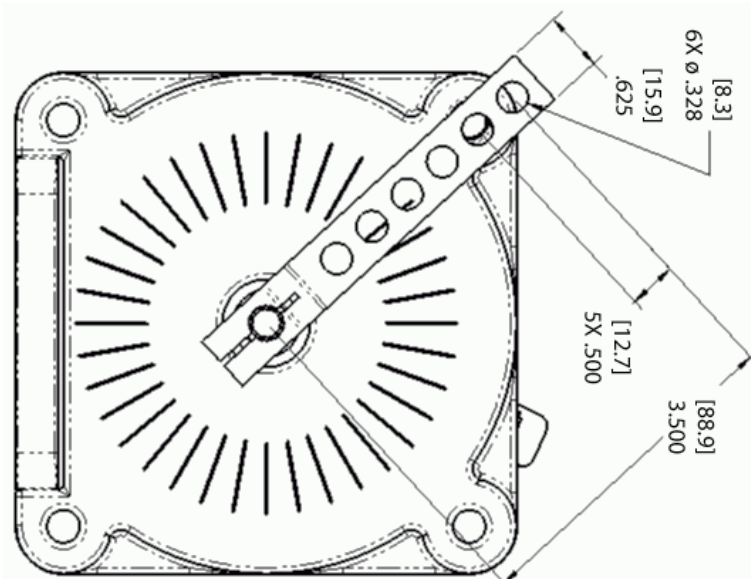
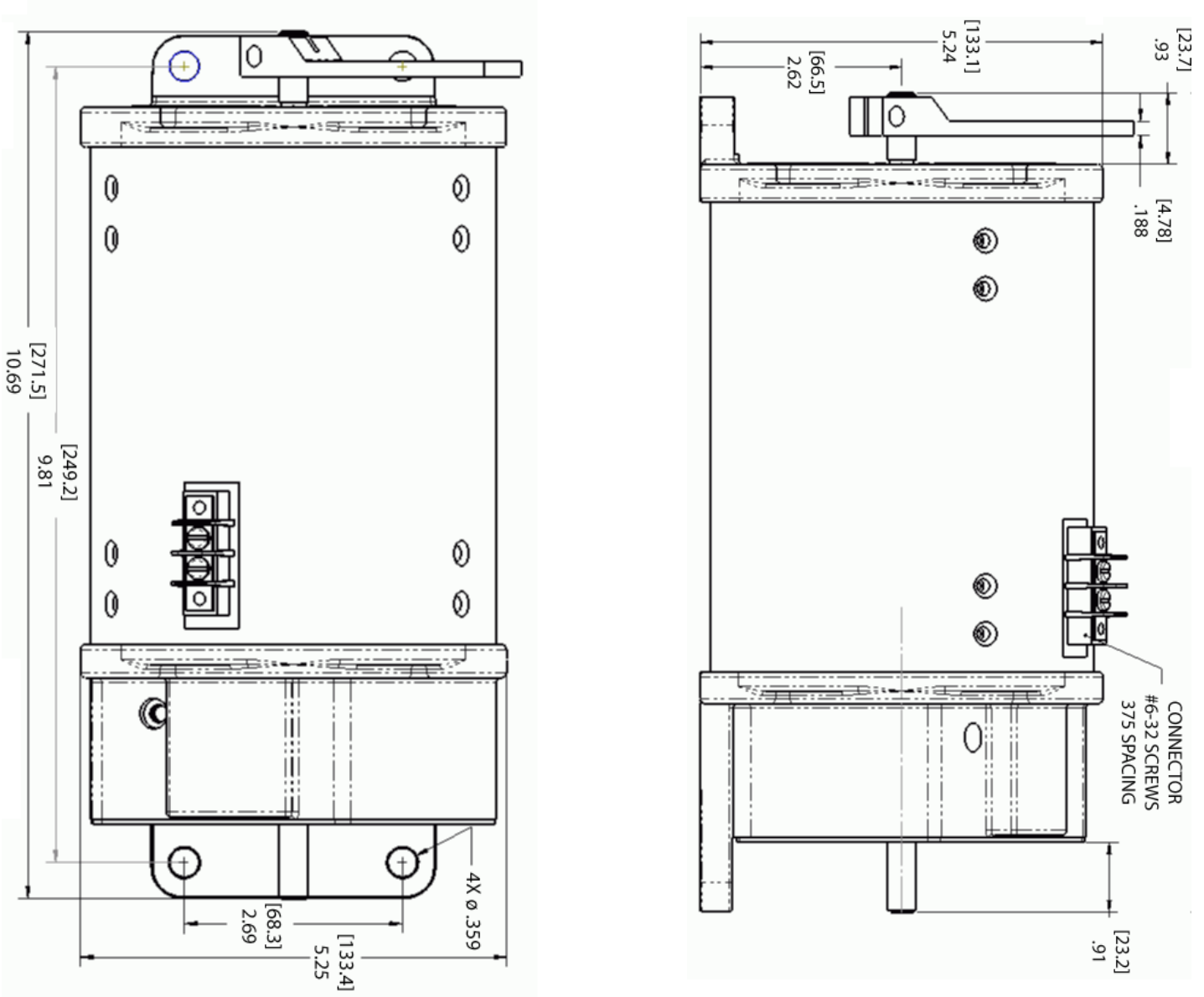

Dimension Units
 [X.XX] — [mm]
 X.XX — in

4

INSTALLATION



An overspeed shutdown device, independent of the governor system, must be provided to prevent loss of engine control which may cause personal injury or equipment damage. Do not rely exclusively on the governor system to prevent overspeed. A secondary shutoff device such as a fuel solenoid must be used.

The actuator must be rigidly mounted as close as possible to the engine throttle lever. The shaft on either end of the ACB2001 may be used. When selecting a mounting location, consideration must be given to possible linkage obstructions. The linkage must be direct, short and as light as possible.

Low friction ball bearing rod ends are recommended and should be used throughout the linkage system. The linkage should be adjusted so that the fuel control minimum and maximum fuel stops are used rather than the internal actuator stops.

INSTALLATION PROCEDURE

1. Drill the actuator mounting holes in a prefabricated mounting bracket. The mounting hole configuration is illustrated in Section 3, Outline Diagram. The position of the Actuator on the Mounting Bracket must ensure minimal misalignment between each end of the governor system linkage. The linkage Ball Bearing Rod Ends can tolerate a maximum misalignment of 10 degrees.
2. Attach the Actuator Bracket to the selected location on the engine.
Attach the actuator securely to the bracket using 5/16 - 18 or M8 hardware.
3. Adjust and secure the Linkage Rod and Ball Bearing Rod Ends to the Actuator Lever and Fuel Control Levers.

For proportional actuators to operate with linear control systems it is important to obtain a linear relationship between actuator stroke and fuel delivery.

Use the included SR128 Vibration Dampeners as required to limit movement and improve balance.

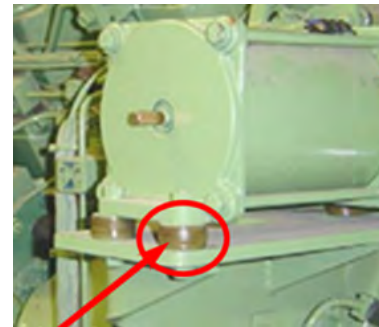
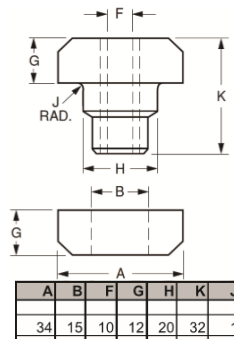

DIESEL FUEL SYSTEMS

For diesel fuel systems, the linkage configuration is typically linear. Cummins PT fuel systems are an exception and should be set up like carbureted applications. The actuator lever should be nearly parallel to the fuel control lever and perpendicular to the linkage rod at the mid-fuel position shown here.

MID FUEL THROTTLE POSITION

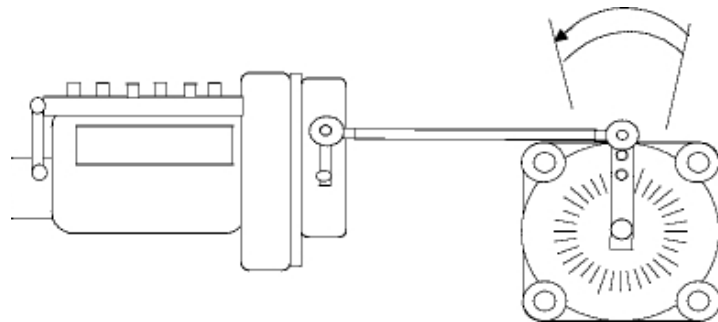

CARBURETED FUEL SYSTEMS

For Carbureted Fuel Systems, the linkage is typically non-linear. The carburetor butterfly valve lever should be parallel with the actuator lever and the linkage rod should be perpendicular to the actuator lever at the maximum fuel position shown here.

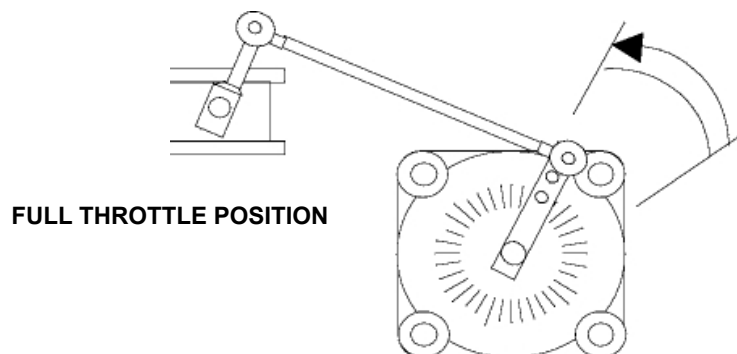

FULL THROTTLE POSITION

5

WIRING

1. Fabricate a cable wiring harness to connect the actuator to the speed control unit. The actuator operates on 24 Volts and for shorter cables (less than 3 m), the recommended wire size for the cable harness is at least 16 awg [15mm]. The wiring must be capable of handling maximum current levels of 10 A and typical current levels of 6A without experiencing a significant voltage drop. Larger gauge wire is necessary for cable lengths greater than 12ft [4m].
2. Secure the actuator end of the harness to safeguard the terminal strip connections from any potential loading or vibration.
3. Connect the cable harness to the ESD5330 Speed Control unit referring to the ESD5330 Installation Manual for details.

6

ADJUSTMENTS

BEFORE STARTING THE ENGINE

Recheck the linkage to ensure that both the linkage and the levers are securely fastened. Manually push the actuator lever to the maximum fuel position to reconfirm that the linkage is not binding and that friction is minimal. Upon releasing the linkage, it must return quickly and smoothly to the minimum fuel position.

LINKAGE ADJUSTMENT

The linkage can be optimized by adjusting it so that the actuator current difference from no engine load to full engine load is approximately 3.5 A.

ACTUATOR LEVER FORCE / TRAVEL

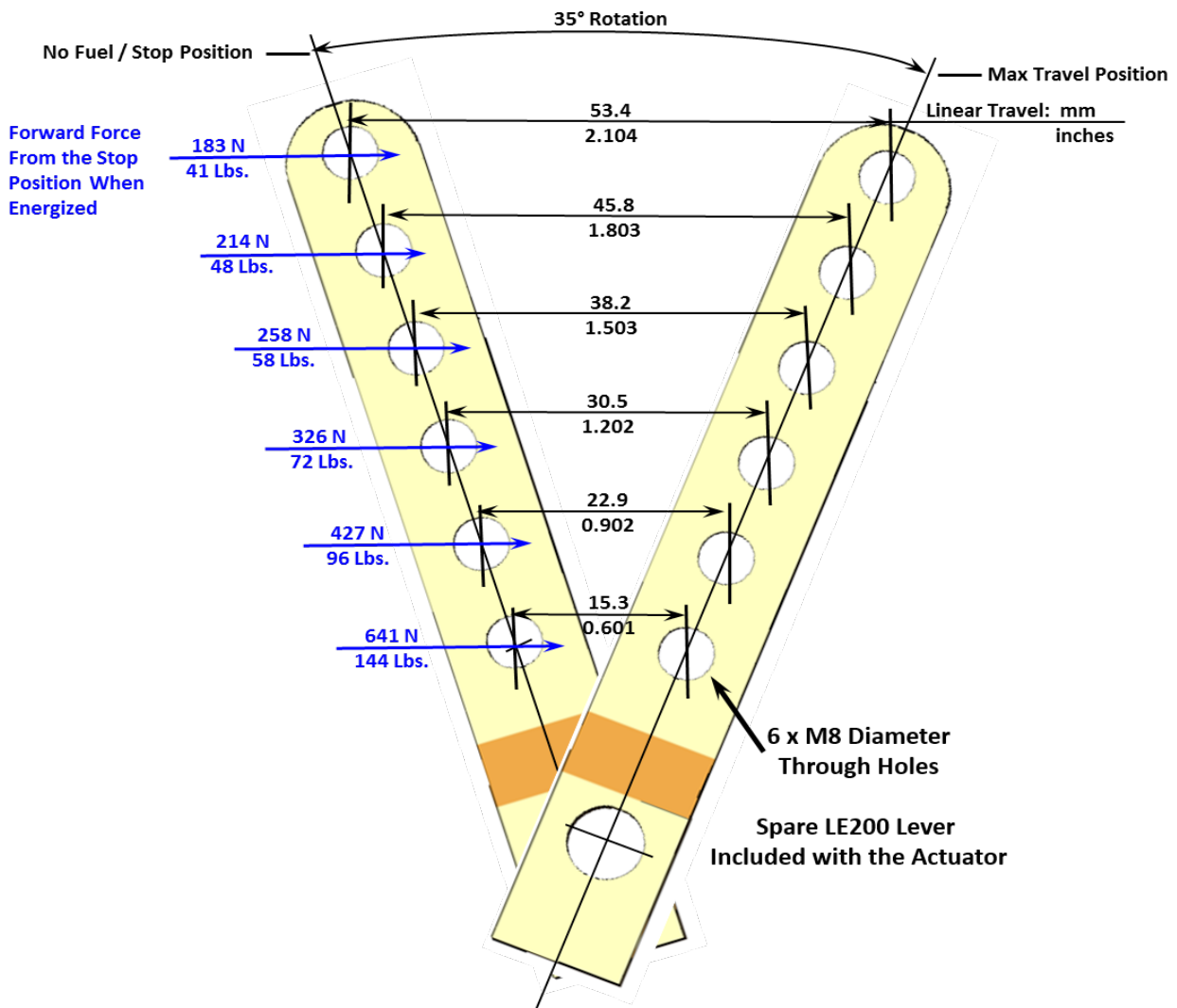

7

TROUBLESHOOTING

If the governor system fails, and the actuator is suspected, the following tests will assist you in confirming the integrity of the actuator.

1. Disconnect the actuator from the control unit. The resistance between the two wires of the actuator should be approximately 2 Ω . The resistance between the actuator housing and either actuator wire should be greater than 1 M Ω .
2. Disconnect any linkage attached to the actuator and manually rotate the lever on the actuator through its entire range. Feel for any kind of friction or binding internal to the actuator.
3. If the actuator passes these tests, the problem is likely elsewhere in the governing system.
4. While reconnecting the external linkage to the actuator, be sure that the external linkage is also free from friction and binding. Always use quality bearing rod ends, avoid linkage connections that are not flexible. See your control unit's publication for further assistance in troubleshooting the governing system.

